

VZ Special 35/35

It destroys everything...



MODEL VZ35/35

Actual Shred Size

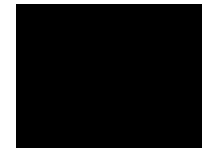

3/4"

Wondering what to do with your video cassettes, floppy disks, CD's, carbon tapes, electronic circuit boards, tin cans and plastic bottles? The solution has arrived!

In the event you have a special need Intimus will be glad to test the capabilities of the machine upon receipt of a sample material.

Materials which contain poisonous, corrosive, corrosion-promoting, or flammable media must not be processed.

The machine is simple to use. You just put your shredding material into the hopper, close the lid and press the start button. When the machine is finished shredding it will turn itself off. You can manually turn it off as well.

The shredded particles fall from the cutting block directly into a commercial garbage bin. The filled bin can then be taken out via a limit switch-secured door on its rollers to be emptied.

MODEL VZ35/35



Features

- Emergency stop switch
- Push button Start & Stop
- Auto Reverse
- Safety Switch
- Warning light control voltage
- Warning light operation
- Hopper cover protects against spraying of shredded materials out of the cutting block
- Removable receptacle

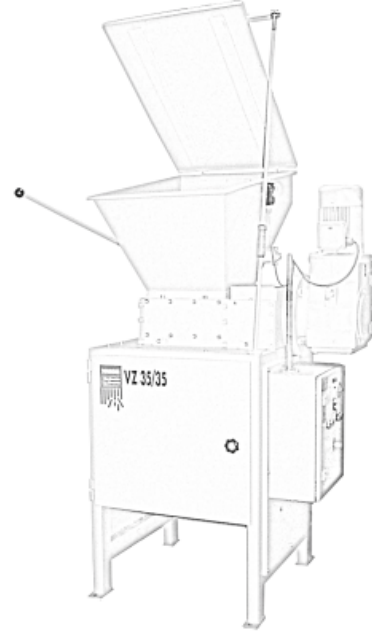

Actual Shred Size



3/4"

Specifications

Shred Size	3/4"
Cutting Zone	14" x 14"
VHS	700-1000 per hr.**
CD's/DVD's	8,000-12,000 per hr.
Boards/Bottles	vary on size & volume
Waste Container	8.47 cubic feet

Rotation	18 minute
Noise Level	70 dBA
Supply Voltage	220v
Power Consumption	6.0hp*
Dimensions	42" x 42"
Plastic Bags	N/A

*Optional 10 hp motor available

** 10hp specs (VHS tapes - up to 1,200 per hour) and (CD's/DVD's - up to 16,000 per hour)